

# HELI

[www.heliforkliftcanada.com](http://www.heliforkliftcanada.com)

BALANCING ECONOMY WITHOUT COMPROMISING QUALITY.

## FG30C - FG60C

Product specifications

### Gas/LPG Cushion Tire Forklifts

3,000 to 6,000lbs Capacity



Legendary Heli Quality

Productivity & Reliability

Powerful Performance

Security & Comfort

2 Year Limited  
Powertrain Warranty

**ISO9001**  
ISO 9001 CERTIFICATION

All Heli forklifts meet or exceed  
ASME B56.1 and CSA B335 Standards

**CE**  
CE CERTIFICATION

# HELI

www.heliforkliftcanada.com



## FG30C - FG60C Gas/LPG Cushion Tire

## FG30C - FG60C

### Product specifications

Model		FG30C	FG35C	FG40C	FG50C	FG60C
Load Capacity	lbs	3000	3500	4000	5000	6000
Load Center	inches	24				
Lifting Speed (w load)	fpm	98				
Lowering Speed (w load)	fpm	94				
Travel Max. Speed	mph	10.76				
Max. Drawbar Pull	lbs	4200	4200	4320	4320	4410
Max. Gradeability	%	28	23	26	23	20
Tilt Angle (F/B)	degrees	5/10				
Overall Height Fork raised	A inches	170				
Max. Fork Height	B inches	130				
Overall Height (w mast)	C inches	80.5	80.5	89	89	87
Free Lift	E inches	6.3				
Overall Length (w fork)	H inches	120.2	121.4	124.8	131.9	138.6
Overall Length (w/o fork)	I inches	84.2	85.4	88.8	89.9	96.6
Min. Under-Clearance	G inches	3				
Overhang (Front/Rear)	K/M inches	16.3/16.7	16.3/16.9	16/18	16/19	17.7/21.3
Wheel Base	L inches	53	53	55	55	59
Overall Height (w Overhead Guard)	P inches	83				
Overall Width	Q inches	38.9	38.9	42	42	45
Opening of Forks	R inches	7.8/37.4	7.8/37.4	9.6/40	9.6/40	9.8/43
Tread (Front/Rear)	S/T inches	32.5/31.9	32.5/31.9	35.5/35.4	35.5/35.4	37/38.2
Min. Intersecting Aisle	X inches	83.4	84.6	94.2	97.2	100
Min. Turning Radius (Outside)	W inches	73.2	74.8	78.1	80.1	81.9
Engine Model	J/U/F	Nissan K21			Nissan K25	
Rated Horsepower (SAE)	hp/rpm	56/2700			60/2700	
Rated Torque (SAE)		119/1600			142/1600	
Battery Voltage/Capacity	V/Ah	12/60				
Tire (Front)		21x6x15-2 or 21x7x15-2		21x7x15-2		22x8x16-2 or 22x9x16-2
Tire (Rear)		14x4 1/2x8		16 1/4x6x11-1/4-2		18x6x12 1/8-2
Service Weight	lbs	5950	6450	7010	7950	9400

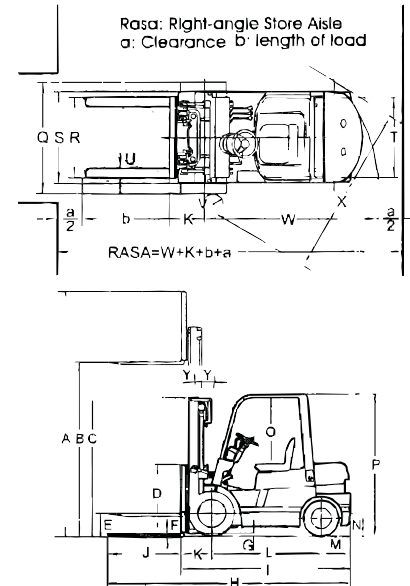

**ISO9001**  
ISO 9001 CERTIFICATION

**CE**  
CE CERTIFICATION

### Options include:

various masts up to 236"  
sideshifts and attachments  
full cabs and rainguards  
air pre-cleaners  
additional lights

All Heli forklifts meet or exceed ASME B56.1 and CSA B335 Standards

Proud to be your authorized Heli Forklift Canada dealer:

## Heli Forklift Canada

402 Allanburg Rd.  
Thorold, ON L2V 1A4  
1-877-435-4352 905-227-7554  
www.heliforkliftcanada.com  
sales@heliforkliftcanada.com